

L SERIES PASSENGER CARS

Assembly Instructions.

Details of the prototype have been covered in separate notes.

Recommended adhesives: Superglue for the body shell with an acrylic contact cement to secure the windows in place eg. Selleys Kwik Grip. Note: Some brands of superglue do not appear to work on this plastic. Test on a piece of scrap beforehand.

1. Remove flash from windows with a sharp knife. Take care to avoid damaging window frames and crown light dividers.
2. Cut the clear glazing material to suit window openings and put aside till the car is assembled and painted. Do not remove the plastic coating until ready to glue the windows in place.
3. Assemble the sides and ends. Trial fit before gluing. Align the pieces so that the roof gutter and the top of the headboard are flush with the corresponding profile of the end. (Diagram 1.) Ensure this assembly is square and not twisted. Terminal set cars (HFL's) have blank ends at the luggage compartment end.
4. Fit the roof into this assembly and fill the remaining join with body filler. Tamiya Plastic Filler is recommended. Smooth off any irregularities with wet and dry sandpaper wrapped over a small block. All roofs fit so that the vents line up with the centre window of each compartment. Codes are marked on one end of each roof.
5. Drill stocks on buffer beams with a No. 64 drill to accept the brass buffers. Glue in position so that the buffer head is hard against the stock. This will provide clearance for close coupling. Glue the buffer beam to the body assembly. Two buffer beams with long stocks are provided with sets. These go on the blank ends of the terminal cars.
6. Glue the underbody detail to the floor castings as shown in Diagram 2. Note that some cars were "wired" and therefore did not have generators and battery boxes.
7. Fit 2AA bogies (AR Kits recommended) and check coupler height. Kadee couplers are designed to be mounted directly onto the mounting pad at each end of the floor.
8. Glue a piece of 8mm angle to the inside of each end. This should sit 2.5mm above the coupler recess in the buffer beam. The floor can now be positioned. Note the sribed lines that correspond to the location of the centre door. Locate the couplers and drill through the mounting hole. By extending this through the angle, it can then be tapped or a nut glued on top to allow the coupler mounting screw to hold the floor in place. (Diagram 3.)
9. Fit truss rods as per Diagram 4. To allow greater swing on the bogies for small radius curves, the truss rod should have a kink in it. (Diag. 4a) This may not be necessary if narrower bogies than AR Kits are used.
10. Fit steps under the centre doors as shown in Diagram 5. Refer to Table 1. to work out which steps fit each car. Bend and fit handrails from 10 thou brass wire.

11. Prior to painting it is recommended that the model is washed with warm water and detergent then thoroughly rinsed and allowed to dry. The model must first be primed with a lacquer primer eg. Floquil otherwise the finishing coats may not adhere. Details of paint schemes are mentioned in the Prototype Notes. Apply decals.

12. Finally, glue the precut window material in place after removing the protective plastic layer. Use white styrene sheet for the toilet windows.

DIAGRAM 1

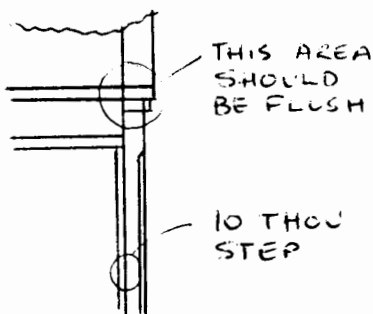

DIAGRAM 3

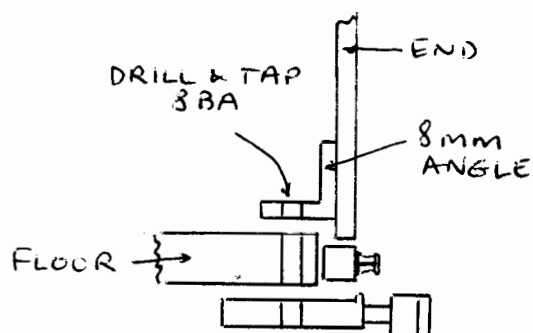
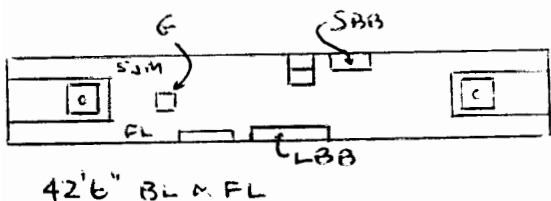
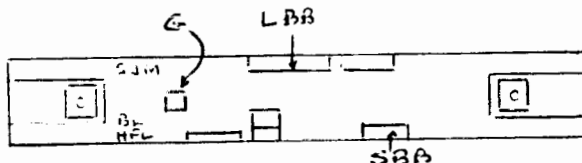

DIAGRAM 2



42'6" BL & FL

G - GENERATOR LBB - LARGE



46' BL & HFL & FL

SBB - SMALL BATTERY BOX

DIAGRAM A

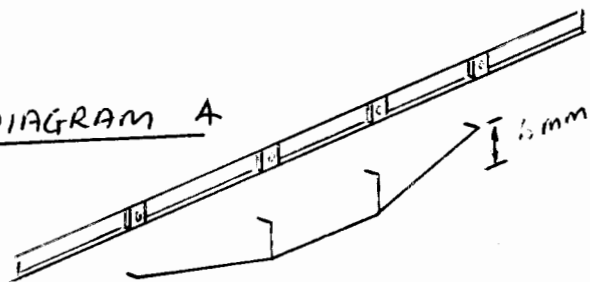

TABLE 1.

Code	Step Length
42'6" BL	24 mm
46' BL	18 mm
42'6" FL	22 mm
HFL	15 mm
RFL	17 mm

DIAG 4a

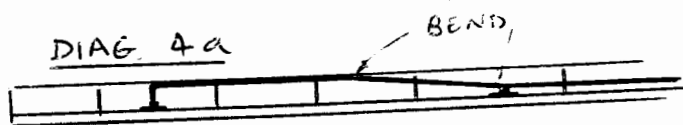

DIAGRAM 5

